

# Inductive Sensors



Housing Style	Part Number	ID Number	Features	Sensing Range (mm)	Output	
<b>18 mm - Embeddable, eurofast® Connection</b> 	Bi 8U-EM18-AN6X-H1141	M1644738	<i>Uprox+</i> , Stainless steel	8	3-Wire DC NPN	
	Bi 8U-EM18WD-AN6X-H1141	M1634839	<i>Uprox+</i> , Washdown	8		
	Bi 8U-M18-AN6X-H1141	M1644737	<i>Uprox+</i>	8		
	Bi 8U-MT18-AN6X-H1141	M1644739	<i>Uprox+</i> , Teflon	8		
		Bi 8U-EM18-AP6X-H1141	M1644734	<i>Uprox+</i> , Stainless steel	8	3-Wire DC PNP
		Bi 8U-EM18WD-AP6X-H1141	M1634816	<i>Uprox+</i> , Washdown	8	
		Bi 8U-M18-AP6X-H1141	M1644731	<i>Uprox+</i>	8	
		Bi 8U-MT18-AP6X-H1141	M1644730	<i>Uprox+</i> , Teflon	8	
		Bi 8U-MT18M-AP6X2-H1141*	M1644740	<i>Uprox+</i> , Dual LED's	8	
		Ni 15U-EM18-AN6X-H1141	M1635336	<i>Uprox+</i> , Stainless steel	15	
Ni 15U-EM18WD-AN6X-H1141	M1634835	<i>Uprox+</i> , Washdown	15			
Ni 15U-M18-AN6X-H1141	M1635335	<i>Uprox+</i>	15			
Ni 15U-MT18-AN6X-H1141	M1635337	<i>Uprox+</i> , Teflon	15			
<b>18 mm - Embeddable, eurofast Connection</b> 	Ni 15U-EM18-AP6X-H1141	M1635332	<i>Uprox+</i> , Stainless steel	15	3-Wire DC PNP	
	Ni 15U-EM18WD-AP6X-H1141	M1634818	<i>Uprox+</i> , Washdown	15		
	Ni 15U-M18-AP6X-H1141	M1635331	<i>Uprox+</i>	15		
	Ni 15U-MT18-AP6X-H1141	M1635333	<i>Uprox+</i> , Teflon	15		
	Ni 15U-MT18M-AP6X2-H1141*	M1635338	<i>Uprox+</i> , Dual LED's	15		
	Bi 8U-EM18E-AP6X-H1141	M1634865	<i>Uprox+</i> , Stainless steel	8	3-Wire DC PNP	
	Bi 8U-M18M-VP44X-H1141	M1634877	<i>Uprox+</i>	8	4-Wire DC PNP	

\* MT18M = Barrel length 62 mm.



Voltage	Switching Freq. (Hz)	Operating Current (mA)	Operating Temp. (°C)	Protection	Housing	Face	Power LED	Output LED	Mating Cordset	Wiring Diagram #	Wiring Diagrams
10-30 VDC	1500	≤200	-25 to +75	IP 68	SS	LCP	N/A	YE	RK 4T-*	1	<div style="border: 1px solid black; padding: 5px; margin-bottom: 5px;"> <b>Diagram 1</b> </div> <div style="border: 1px solid black; padding: 5px; margin-bottom: 5px;"> <b>Diagram 2</b> </div> <div style="border: 1px solid black; padding: 5px;"> <b>Diagram 3</b> </div>
	1500	≤200	0 to +85	IP 68, 69K	SS	LCP	N/A	YE	RK 4T-*	1	
	1500	≤200	-25 to +75	IP 68	CPB	LCP	N/A	YE	RK 4T-*	1	
	1500	≤200	-25 to +75	IP 68	TC	LCP	N/A	YE	RK 4T-*	1	
10-30 VDC	1500	≤200	-25 to +75	IP 68	SS	LCP	N/A	YE	RK 4T-*	2	
	1500	≤200	0 to +85	IP 68, 69K	SS	LCP	N/A	YE	RK 4T-*	2	
	1500	≤200	-25 to +75	IP 68	CPB	LCP	N/A	YE	RK 4T-*	2	
	1500	≤200	-25 to +75	IP 68	TC	LCP	N/A	YE	RK 4T-*	2	
	1500	≤200	-25 to +75	IP 68	TC	LCP	GN	YE	RK 4T-*	2	
10-30 VDC	1000	≤200	-25 to +75	IP 68	SS	LCP	N/A	YE	RK 4T-*	1	
	1000	≤200	0 to +85	IP 68, 69K	SS	LCP	N/A	YE	RK 4T-*	1	
	1000	≤200	-25 to +75	IP 68	CPB	LCP	N/A	YE	RK 4T-*	1	
	1000	≤200	-25 to +75	IP 68	TC	LCP	N/A	YE	RK 4T-*	1	
10-30 VDC	1000	≤200	-25 to +75	IP 68	SS	LCP	N/A	YE	RK 4T-*	2	
	1000	≤200	0 to +85	IP 68, 69K	SS	LCP	N/A	YE	RK 4T-*	2	
	1000	≤200	-25 to +75	IP 68	CPB	LCP	N/A	YE	RK 4T-*	2	
	1000	≤200	-25 to +75	IP 68	TC	LCP	N/A	YE	RK 4T-*	2	
	1000	≤200	-25 to +75	IP 68	TC	LCP	GN	YE	RK 4T-*	2	
10-30 VDC	1000	≤200	-25 to +75	IP 68	SS	LCP	N/A	YE	RK 4T-*	2	
10-55 VDC	1500	≤200	-30 to +85	IP 68	CPB	LCP	N/A	YE	RK 4,4T-*	3	

Uprox+

\* Length in meters.

WIRING DIAGRAM

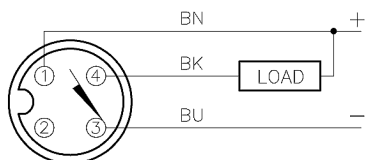

OUTPUT: AN6X

SHORT-CIRCUIT AND OVERLOAD PROTECTED

LOCKNUT LN-MT18

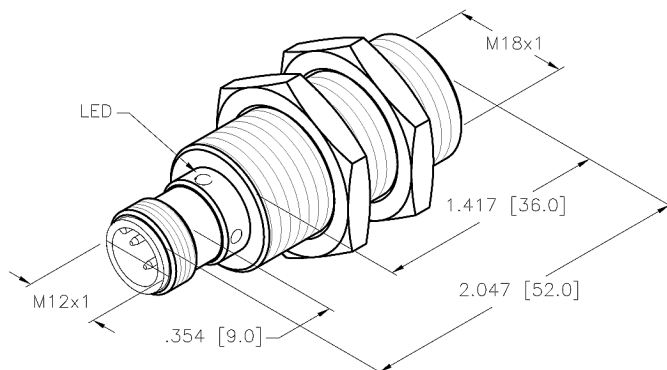
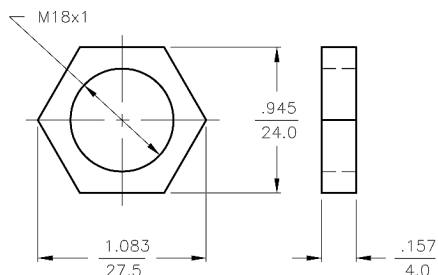

SPECIFICATIONS

RATED OPERATING DISTANCE	8mm [.315"]
MOUNTING MODE	FLUSH
TEMPERATURE DRIFT	≤±10%
HYSTERESIS	3-15%
MIN. REPEAT ACCURACY	≤2%
OPERATING TEMPERATURE	-30°C to +85°C (-22°F to +185°F)
RATED OPERATIONAL VOLTAGE	10-30 VDC
MAX. RIPPLE	≤ 10%
RATED OPERATIONAL CURRENT	≤ 200 mA
NO-LOAD CURRENT	≤ 15 mA
MAX. OFF-STATE CURRENT	≤ 0.1 mA
RATED INSULATION VOLTAGE	≤ 0.5 kV
SHORT-CIRCUIT PROTECTION	YES
MAX. VOLTAGE DROP	≤ 1.8 V
WIRE BREAKAGE PROTECTION	INCORPORATED
REVERSE POLARITY PROTECTION	INCORPORATED
OUTPUT FUNCTION	3-WIRE, NORMALLY OPEN, NPN
MAX. SWITCHING FREQUENCY	≤ 1.5 kHz
HOUSING MATERIAL	BRASS, CHROME PLATED
ACTIVE FACE	PLASTIC, LCP-GF30
CONNECTION	M12x1
VIBRATION RESISTANCE	55 Hz (IN ALL 3 PLANES)
SHOCK RESISTANCE	30 g, 11 ms
DEGREE OF PROTECTION	IP 68
SWITCHING STATUS INDICATION	LED: YELLOW

SOURCE DRAWING - FOR REFERENCE ONLY

RELATED DOCUMENTS		3RD ANGLE PROJECTION		THIS DRAWING IS PROPERTY OF TURCK INC. USE OF THIS DOCUMENT WITHOUT WRITTEN PERMISSION IS PROHIBITED.		 High Technology Sensors and Automation Controls	
1.			DRFT	RDS	DATE 05/09/06	DESCRIPTION	
2.			DSGN	TB	SCALE 1=1.0	BI 8U-M18-AN6X-H1141	
3.		TOLERANCES UNLESS OTHERWISE SPECIFIED .X ±0.02 .XX ±0.01 .XXX ±0.005 ANGLES ±1° ALL MILLIMETER DIMENSIONS ARE REFERENCE ONLY	UNIT OF MEASUREMENT			IDENTIFICATION NO.	
4.			<b>INCH [ MILLIMETER ]</b>			M1644737	
MATERIAL		DO NOT SCALE THIS DRAWING			FILE: M1644737		REV
FINISH							A
A	DRAWING RELEASE	RDS	05/09/06				
REV	DESCRIPTION	BY	DATE	ECO NO.	SHEET 1 OF 1		